

J. P. JOHANSSON.
CENTRIFUGAL LIQUID SEPARATOR.
APPLICATION FILED FEB. 16, 1906.

963,577.

Patented July 5, 1910.

6 SHEETS—SHEET 1.

Fig. 1.

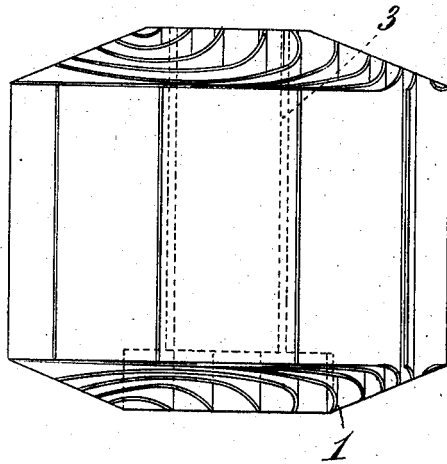
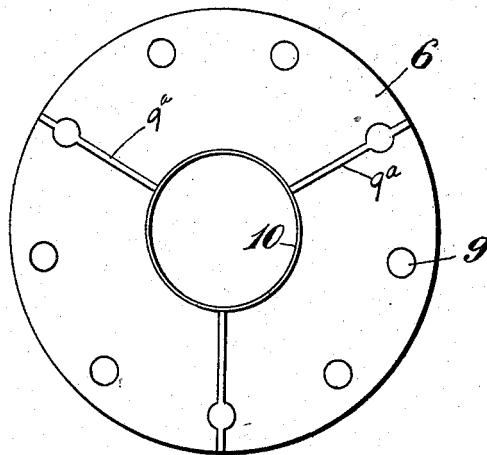

Fig. 6.



Witnesses
F. N. Wiman
William J. Firth

Inventor
Johan Petter Johansson
By his Attorney *Hann*

J. P. JOHANSSON.
 CENTRIFUGAL LIQUID SEPARATOR.
 APPLICATION FILED FEB. 16, 1906.

963,577.

Patented July 5, 1910.

6 SHEETS—SHEET 2.

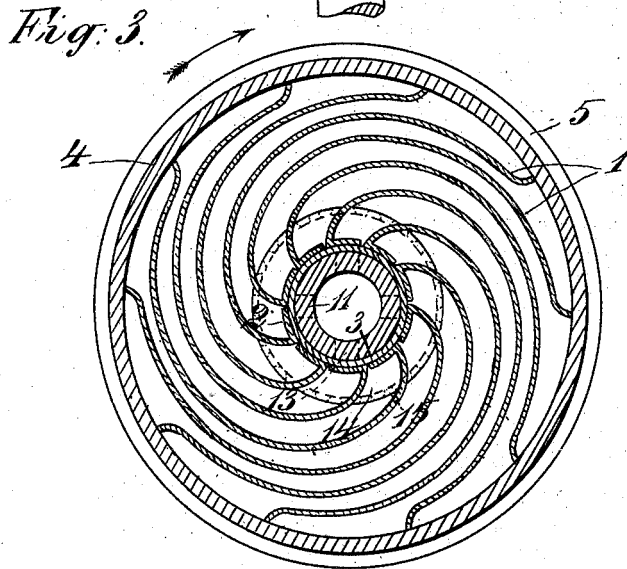
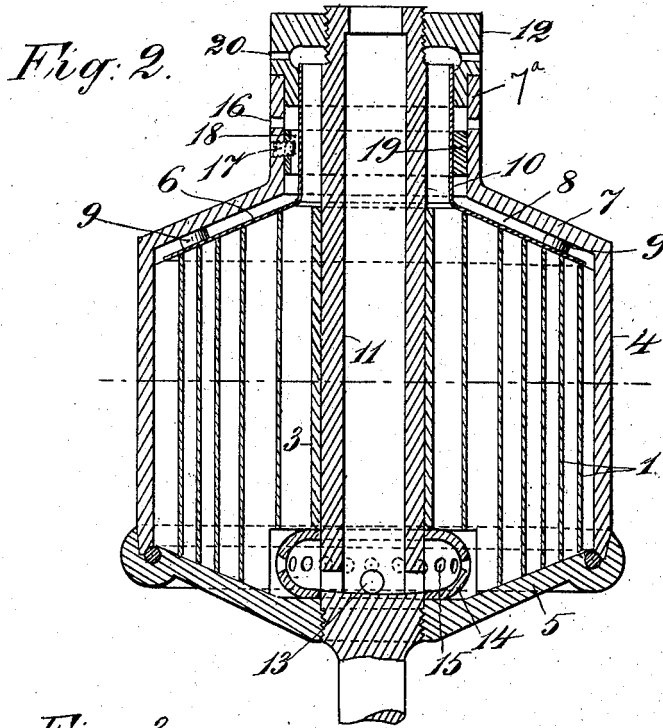

Witnesses
J. H. Alimay
William J. Firth

Inventor
 Johan Petter Johansson
 By his Attorney *Henry Gannett*

J. P. JOHANSSON.
CENTRIFUGAL LIQUID SEPARATOR.
APPLICATION FILED FEB. 16, 1906.

963,577.

Patented July 5, 1910.

6 SHEETS—SHEET 3.

Fig. 7.

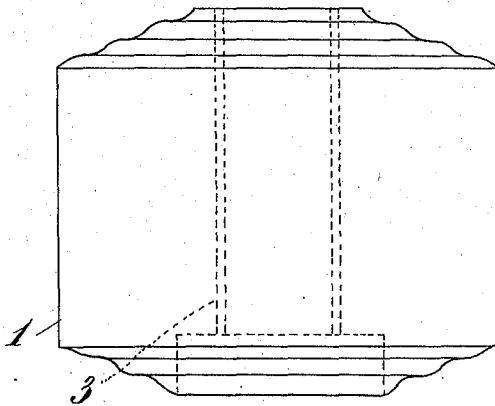

Fig. 4.

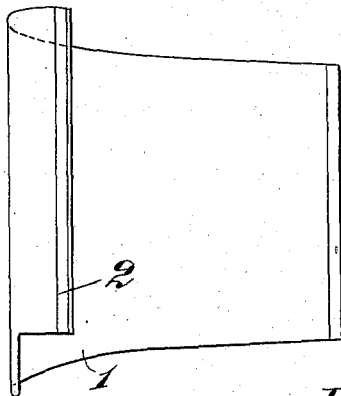
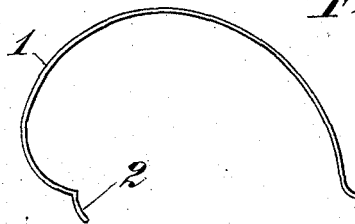

Fig. 5.



Witnesses
F. H. Wiman
William J. Firth

Inventor
Johan Petter Johansson
By *Leis Attorney* *Henny Canudo*

J. P. JOHANSSON.
 CENTRIFUGAL LIQUID SEPARATOR.
 APPLICATION FILED FEB. 16, 1906.

963,577.

Patented July 5, 1910.

5 SHEETS—SHEET 4.

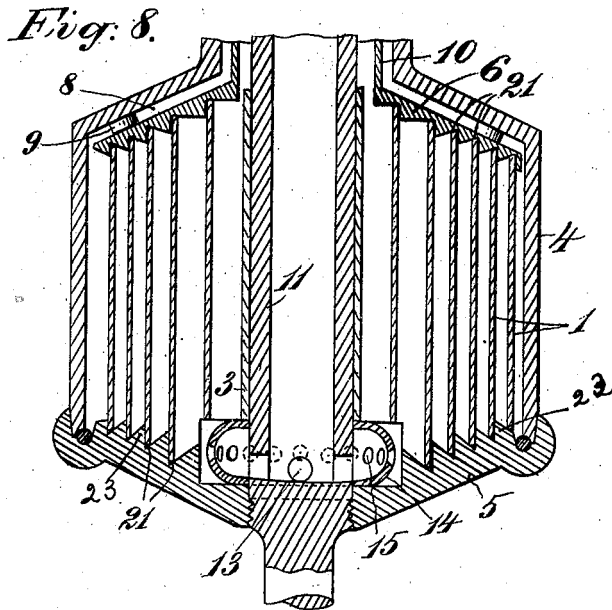

Fig. 9.

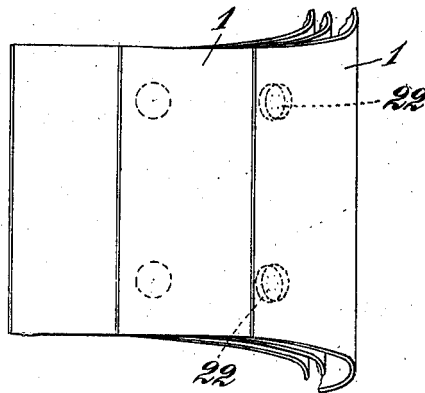
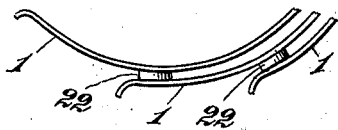

Fig. 10.



Witnesses
W. H. Smith
Luth

Inventor
Johan Petter Johansson
 By his Attorney *Steen Leonard*

J. P. JOHANSSON.
CENTRIFUGAL LIQUID SEPARATOR.
APPLICATION FILED FEB. 16, 1906.

963,577.

Patented July 5, 1910.

5 SHEETS—SHEET 5.

Fig. 11.

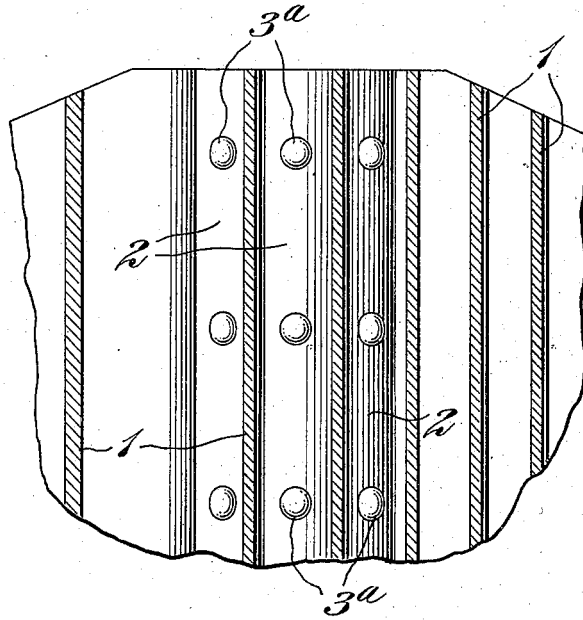
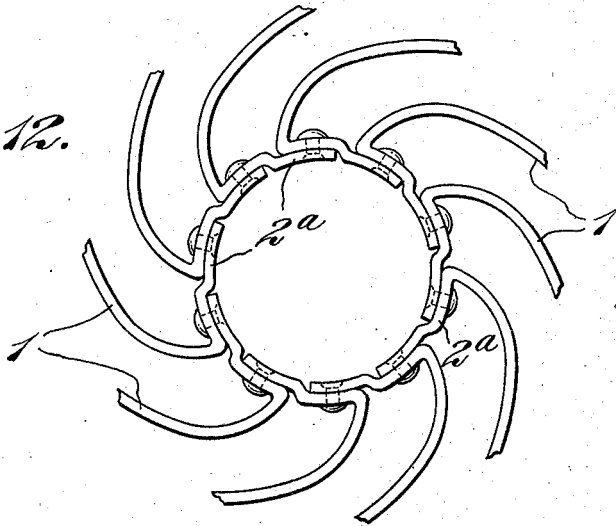

Fig. 12.



WITNESSES

M. C. Abbott
Hydromech.

INVENTOR

Johan Petter Johansson

J. P. Johansson BY
ATTORNEY

UNITED STATES PATENT OFFICE.

JOHAN PETTER JOHANSSON, OF ENKÖPING, SWEDEN, ASSIGNOR TO ENKOPINGS
MEKANISKA VERKSTADS AKTIEBOLAG, OF ENKÖPING, SWEDEN.

CENTRIFUGAL LIQUID-SEPARATOR.

963,577.

Specification of Letters Patent.

Patented July 5, 1910.

Application filed February 16, 1906. Serial No. 301,444.

To all whom it may concern:

Be it known that I, JOHAN PETTER JOHANSSON, a subject of the King of Sweden, and resident of Enköping, in the Kingdom of Sweden, have invented certain new and useful Improvements in or Relating to Centrifugal Liquid-Separators, of which the following is a specification, reference being had therein to the accompanying drawings.

This invention relates to certain improvements in centrifugal separators, and more particularly in that class of such devices wherein are employed liners formed from thin plates adapted to be grouped in spaced circular arrangement within the separator drum so as to surround the inlet or admission passage thereof, and the object of the invention is to provide novel and improved means for maintaining such liner plates in spaced relation against the stress imposed upon them during the centrifugal operation, whereby the liner is braced and strengthened to withstand such stress, and the employment of projections or spacing devices such as have heretofore been provided upon the plates themselves, is dispensed with. Heretofore, in such structures, the liner plates have usually been loosely connected together at their inner and outer parts to permit the liner to be conveniently inserted and removed from the drum, and in order to prevent such plates from being pressed in contact with each other during the centrifugal operation, whereby the flow of liquid between them would be interfered with, it has been customary to provide such plates with spacing pieces or projections, and as the plates are usually formed from comparatively thin material, it has been customary to locate these spacing pieces or projections at sufficiently short intervals to prevent bending or deformation of the plates at their intervening unsupported parts.

According to the present invention the employment of such spacing pieces or projections is rendered altogether superfluous, the spaces or passages between the liner plates being thus left open and unobstructed throughout their entire extent, so as to permit of being readily and conveniently accessible for cleansing without requiring movement of the plates away from each other, whereby it is permitted to connect the plates fixedly together, so as to impart such strength and stability to the liner as

is desirable, and to materially facilitate the handling of the same.

The invention consists, in part, in a liner comprising a series of plates in circular arrangement having upper and lower edge portions reversely inclined to the axis of the liner and extended in directions approaching each other toward the perimeter thereof, and adapted for contact upon similarly formed surfaces at top and bottom of a separator drum.

The invention also consists in the combination of a liner of this general character with a centrifugal drum the upper and lower parts of which have surfaces which are extended in directions reversely inclined to the axis of the drum and approaching each other toward the perimeter thereof, and are adapted for secure engagement with the upper and lower edges of the liner plates to maintain the latter in relation during the centrifugal operation.

Another part of the invention consists in a separator drum the upper and lower parts of which have spaced projections which are capable of engagement with the upper and lower edge portions of the liner plates in such a manner as to effectively retain said plates in spaced relation during the centrifugal operation.

The invention also contemplates certain novel features of the construction, and combinations and arrangements of the several parts of the improved centrifugal separator and liner, whereby certain important advantages are attained, and the structures are rendered simpler, less expensive, and otherwise better adapted, and more convenient for use, all as will be hereinafter fully set forth.

The novel features of the invention will be carefully defined in the claims.

In order that my improvements may be the better understood I will now describe the same with reference to the accompanying drawings, wherein—

Figure 1 is a side elevation of a liner constructed according to my invention; Fig. 2 is a vertical section taken axially through a separator drum embodying my improvements, the improved liner being shown in position for use therein; Fig. 3 is a sectional view taken horizontally through the drum and liner shown in Fig. 2; Fig. 4 is a side view of a single plate detached from the

liner; Fig. 5 is a top edge view of the plate shown in Fig. 4; Fig. 6 is a top view of an inner reinforced cap or clamping member employed within the separator drum for engagement with the upper edges of the liner plates for holding them in spaced relation; Fig. 7 is a view similar to Fig. 1, but showing another formation of liner embodying my invention; Fig. 8 is a view similar to Fig. 2, but showing another formation of separator drum embodying my improvements; Fig. 9 is a side view showing another formation of the liner plates embodying my invention, and Fig. 10 is a top edge view of the plates shown in Fig. 9. Fig. 11, a fragmentary view partly in section, and partly in elevation of a certain detail of the invention. Fig. 12 is a view in top plan illustrating a modified detail of the invention.

Referring first to Figs. 1 to 6, the liner comprises a plurality of spaced plates 1, 1, arranged in a circular series and fixedly connected at their inner vertical edges by means of a tube 3, the inner edge portion of each plate 1 being provided, in the structure herein illustrated, with a vertically directed flange 2, integrally produced upon it, which is riveted or otherwise secured upon the peripheral surface of the tube 3, in such a manner as to connect said plates securely together to form a firm and stable body portion of sufficient rigidity to permit of being conveniently handled and cleansed. The tube 3 may, however, be dispensed with when desired, and in such event, the flanges 2, 2 may be lapped and riveted together so as to afford a tubular structure at the axis of the body portion. The walls of the tube may be, in either case, imperforate or perforated. The lateral surfaces of the plates 1, 1, which form the walls of the intervening spaces or passages, are left smooth and regular, and when the plates are fixedly connected, as above set forth, said spaces or passages are readily accessible throughout their entire extent when the liner is removed from the drum, so that the plates may be conveniently and effectively cleansed without being separated, as for example, by means of a cloth or brush inserted between the plates. The upper and lower edge portions of the plates 1, 1 are inclined in reverse directions with respect to the axis of the liner, the width of each plate, measured parallel with the axis, being greater at the inner edge of the plate than at its outer or peripheral portion, and the inclinations of such upper and lower edge portions of each plate are of such a nature as to approach each other gradually toward the perimeter of the liner, so that reverse conoid formations are imparted to the top and bottom of the body portion, as clearly shown in Figs. 1 and 2. The chamber of the centrifugal drum 4, wherein the

liner is received is also provided, at top and bottom, with reverse conoid surfaces, which conform to the reverse conoid surfaces at top and bottom of the liner, and approach each other toward the perimeter of the drum and are adapted for accurate contact upon the inclined upper and lower edge portions of the several liner plates, so as to permit said plates to be securely clamped between such reverse conoid surfaces of the drum and to be thereby securely held against deformation or bending under the centrifugal force and stress to which they are exposed during the operation of the device.

As shown in Fig. 2, the conoid surface of the drum whereon the lower inclined edge portions of the liner plates are engaged, is formed upon the drum bottom, as clearly shown at 5 in the drawing, while the reverse conoid surface for contact with the reversely inclined upper edge portions of said liner plates, is formed upon an inner or auxiliary cap or clamping member 6, which is removably arranged within the upper part of the drum, and has its lower conical surface arranged to fit accurately upon the said inclined upper edge portions of the liner plates, and is provided upon its top surface with projections or reinforcements 9 and 9^a, which are adapted for engagement upon the under or inner surface of the drum top or cover 7 so as to securely hold said inner or auxiliary cap or clamping member 6 in position spaced from the top or cover 7 of the drum for effective clamping engagement with the said liner plates. By this arrangement a space or passage 8 is afforded between the inner auxiliary cap or member 6 and the inclined top or cover 7 of the drum, which space or passage 8 permits the flow of the blue milk up through the neck of the drum to the blue milk outlet 16 in a well known manner, and as herein shown the reinforcements 9^a are made in the form of flanges extended radially from the neck 10 of the inner auxiliary cap or clamping member 6 and serving to direct the blue milk inwardly toward the neck of the drum during its upward flow through said space or passage 8.

11 represents the inlet or admission tube of the drum, which is extended up axially from the bottom thereof, and over which the central tubular part 3 of the improved liner is adapted to be slipped when said liner is applied within the drum for use. The upper end of the tube 11 is screw-threaded to receive a nut 12, which is adapted for secure engagement upon the upwardly directed neck or central extension 7^a of the drum top or cover 7, so as to permit of securely holding the liner clamped between the reverse conoid surfaces at top and bottom of the drum when the parts are assembled during the centrifugal operation.

In this manner, each plate 1 of the improved liner is securely and firmly supported at its upper and lower edge portions by contact upon the reverse conoid surfaces 6 and 5 at top and bottom of the drum, and is thereby effectively prevented from being bent or deformed during the centrifugal operation without the employment of spacing pieces or projections such as are ordinarily provided upon the liner plates for this purpose.

The full milk admitted to the tube 11 escapes from the lower part thereof at the apertures 13, a hollow ring like distributing member 14 being removably held upon the lower part of said tube 11 below the liner, in position to receive within its interior chamber the full milk discharged at said apertures 13, and to distribute the same uniformly to the several spaces or passages between the liner plates 1, 1 through apertures 15 in its perimetral wall. Each plate of the liner has its lower edge portion notched out or cut away adjacent to the center of the liner in order to permit the liner to be positioned over the member 14 to bring the spaces between the liner plates closely adjacent to the apertures 15 of said member.

The upturned neck portions or central extensions 7^a and 10 of the drum top 7 and inner or auxiliary cap or clamping member 6 are spaced apart, as clearly shown in Fig. 2 to afford between them an annular space into the lower part of which the blue milk is discharged from the space or passage 8, and the neck portion or extension 10 of the inner cap or member 6 is spaced apart from the inlet tube 11 to produce a similar annular passage through which the cream flows upwardly to the cream outlet 20, and in order to permit of controlling the level of the blue milk and cream within said annular chambers or spaces, I provide a ring or partition 19 extended across the annular blue milk space between the extensions 7^a and 10 of the drum top 7 and cap or member 6, which ring or partition has a constricted passage 18 extended through it for the flow of the blue milk to the outlet 16, a screw 17 being adjustably held upon the extension 7^a of the drum top 7 with its tip entering said channel 18 so as to permit of varying the capacity of said channel for the flow of the blue milk by simple adjustment of said screw.

While the employment of the auxiliary or inner cap or clamping member 6 for contact with the liner affords a very convenient construction, the invention is not limited thereto, since it will be evident that the conoid top of the liner may be engaged directly upon the correspondingly formed top surface of the drum, the blue milk being discharged through appropriate devices, as pipes or passages communicating with the

outer part of the drum. It will also be evident that the upper and lower surfaces of the liner and the upper and lower surfaces of the drum which contact therewith need not, according to the broad principle of my invention, be given regular or true conoid forms, but may be spherical or irregularly formed. For example in Fig. 7 I have shown the liner provided at top and bottom with reversely inclined wavy or step-like surfaces which gradually approach each other toward the perimeter of the structure, and are adapted to be clamped between correspondingly formed surfaces at top and bottom of the drum.

In Fig. 8 I have shown an embodiment of my invention wherein the top and bottom of the separator drum have grooves 21, 21 to receive the edges of the liner plates, the surfaces of said grooves which have clamping engagement with said edges of the liner plates being reversely inclined so as to accurately conform to the inclinations of said edges. In this construction the grooves 21, 21 are separated by projections 23, 23 which are adapted for engagement against the outer sides of the liner plates adjacent to the edges thereof so as to the more securely maintain said plates in position against the stress imposed upon the plates during the centrifugal operation. In cases where the liner plates are exceptionally wide, measured vertically, it may sometimes be desirable to provide them at their central parts with spacing pieces or projections 22, 22, as shown in Figs. 9 and 10, so as to lessen the liability of bending which would otherwise be present.

As shown in Fig. 3 the inner portions of the plates adjacent to the flanges 2, are curved for a considerable part of their length with a comparatively great eccentricity with respect to the axes of the liner in order that the spaces or passages between such inner portions of the plates may be as wide as possible adjacent to the center of the liner where the full milk is received. The outer portions of the plates are curved with reduced eccentricity with relation to the axes of the liner in order that the plates shall approach each other adjacent to the perimeter of the liner, the spaces or passages between such outer portions of the plates being thereby reduced in width so that the milk-layers contained therein are very thin where the centrifugal force acts with the greatest power, in order that the greatest efficiency may be attained. The cream will, however, readily pass toward the center its flow being facilitated by rotating the drum and liner in the direction in which the plates are bent, as indicated by the arrow in Fig. 3, so that the flow of the cream will be facilitated by its inertia.

Having thus described my invention, what

I claim and desire to secure by Letters Patent is:

1. A liner for a centrifugal separator having plates the upper and lower edge portions of each of which are extended in directions reversely inclined to the axis of the liner and approaching each other toward the perimeter thereof, said upper and lower edge portions of said plates being capable of engagement with similarly formed surfaces at top and bottom of a drum.

2. A liner for a centrifugal separator having plates curved in cross section, the upper and lower edges of each plate being extended in directions reversely inclined to the axis of the liner and approaching each other toward the perimeter thereof, and being capable of engagement with similarly formed surfaces at top and bottom of a drum.

3. A liner for a centrifugal separator having fixedly connected plates the upper and lower edge portions of each of which are extended in directions reversely inclined to the axis of the liner and approaching each other toward the perimeter thereof, said upper and lower edge portions of said plates being capable of engagement with similarly formed surfaces at top and bottom of a drum.

4. A liner for a centrifugal separator having plates which are in cross section eccentrically curved with relation to the axis of the liner, and the upper and lower edge portions of each of which are extended in directions reversely inclined to the axis of the liner and approaching each other toward the perimeter thereof, the eccentricity of each plate being reduced adjacent to the perimeter of the liner, and said upper and lower edge portions of each plate being capable of engagement with similarly formed surfaces at top and bottom of a drum.

5. A liner for a centrifugal separator having fixedly connected plates which are, in cross section, eccentrically curved with relation to the axis of the liner, and the upper and lower edge portions of each of which are extended in directions reversely inclined to the axis of the liner and approaching each other toward the perimeter thereof, the eccentricity of each plate being reduced adjacent to the perimeter of the liner, and said upper and lower edge portions of each plate being capable of engagement with similarly formed surfaces at top and bottom of a drum.

6. A liner for a centrifugal separator having spaced plates each having its inner part provided with an integral angular laterally directed portion which is rigidly connected with an adjacent plate.

7. A liner for a centrifugal separator having spaced plates, each of which has a laterally directed portion affording a rigid connection with an adjacent plate, the upper

and lower edge portions of each plate being extended in directions reversely inclined to the axis of the liner and being capable of engagement with similarly formed surfaces at the top and bottom of a drum.

8. A centrifugal separator comprising a drum having its respective upper and lower parts each provided with a series of spaced projections, and a liner adapted for arrangement within the drum and comprising a series of plates the upper and lower edge portions of which are adapted for engagement upon the projections of the respective series at the upper and lower parts of the drum.

9. A centrifugal separator comprising a drum having, at its top and bottom, reverse conoid surfaces each provided with a series of spaced projections, and a liner adapted for arrangement within the drum and comprising a series of plates eccentrically curved with relation to the axis of the drum and having upper and lower edge portions extended in directions inclined to the axis of the drum and approaching each other toward the perimeter of the liner and adapted, when the liner is within the drum, for engagement upon the projections of the respective series at top and bottom of the drum.

10. A centrifugal separator comprising a drum having a central tubular part provided with an admission passage, a chambered member extended around and detachably held upon said tubular part with its chamber adapted for communication with the admission passage to receive fluid therefrom, and provided with outlet apertures in its peripheral walls for the discharge of fluid from its chamber, and a liner comprising a series of plates extended in the drum and spaced apart to produce between them a plurality of passages to which the fluid discharged at the peripheral apertures of said member is admitted.

11. A centrifugal separator comprising a drum having a central tubular part provided with an admission passage, a chambered member extended around and detachably held upon said tubular part with its chamber adapted for communication with the admission passage to receive fluid therefrom and provided with outlet apertures in its walls for the discharge of fluid from its chamber, and a liner arranged within the drum and comprising a tubular member removably fitted upon the central tubular part of the drum, and plates fixedly held at their inner edges upon said tubular member and extended therefrom and eccentrically curved in cross-section with respect to the axis of the drum and spaced apart to provide passages between them for the outflow of fluid discharged at the outlets of said chambered member.

70

75

80

85

90

95

100

105

110

115

120

125

130

12. A centrifugal separator having a drum comprising separable upper and lower members provided, at their upper and lower parts with projections in series, a liner adapted for arrangement within the drum and comprising a series of plates, the upper and lower edge portions of which are adapted for engagement upon the projections of the respective series at the upper and lower parts of the separable drum members, and means for holding the separable members of the drum in relation with their series of projections engaged with said liner plates.

13. A centrifugal separator having a drum provided with a chamber the upper and lower parts of which have spaced projections adapted for engagement with the upper and lower edge portions of liner plates to hold such plates in position within the chamber.

14. A centrifugal separator having a drum provided with a chamber, the lower part of which has spaced projections adapted for engagement with the lower edge portions of liner plates, and a clamping member arranged within the upper part of the drum and also provided with spaced projections for engagement with the upper edge portions of such liner plates.

15. A centrifugal separator having a drum provided with a chamber, the lower part of which has spaced grooves adapted to receive the lower edge portions of liner plates, and a clamping member arranged within the upper part of the drum and also provided with spaced projections for engagement with the upper edge portions of said liner plates.

16. A centrifugal separator having a drum provided with a chamber the lower part of which has a surface extended in a direction upwardly inclined from the axis of the drum toward its periphery and adapted for engagement with the lower part of a liner, and a clamping member arranged within the upper part of the drum and provided with a surface extended in a direction downwardly inclined from the axis of the drum toward the periphery thereof and adapted for engagement with the upper part of such liner.

17. A centrifugal separator having a drum provided with a chamber the lower part of which has a conoid surface extended

in a direction upwardly inclined from the axis of the drum toward its periphery and adapted for engagement with the lower part of a liner, and a clamping member arranged within the upper part of the drum and provided with a conoid surface extended in a direction downwardly inclined from the axis of the drum toward the periphery thereof and adapted for engagement with the upper part of such liner.

18. A centrifugal separator having a drum formed of separable parts and provided with a chamber the upper and lower portions of which have spaced grooves adapted to receive the upper and lower edge portions of liner plates to retain said plates in position in said chamber, and means for securing the separable parts of the drum in relation for holding said grooved parts in engagement with the liner plates.

19. A centrifugal separator having a drum formed of separable parts and provided with a chamber the upper and lower portions of which have spaced projections adapted for engagement with the upper and lower edge portions of liner plates to retain said plates in place within the drum, and means for securing the separable parts of the drum in relation for holding said projections in engagement with the liner plates.

20. A centrifugal separator having a drum provided with a chamber the upper and lower parts of which have spaced recesses adapted to receive upper and lower edge portions of liner plates to retain said plates in position within the chamber.

21. A centrifugal separator having a drum formed of separable parts and provided with a chamber the upper and lower portions of which have spaced recesses adapted to receive the upper and lower portions of liner plates to retain said plates in position within said chamber, and means for holding the separable parts of the drum in relation for holding the liner plates engaged in the spaced recesses at the upper and lower portions of the chamber.

In witness whereof I have hereunto signed my name this 31st day of January, 1906, in the presence of two subscribing witnesses.

JOHAN PETTER JOHANSSON.

Witnesses:

CARL FRIBERG,
ROBERT APELGREN.